

MODEL SOLAR ELECTRIC POWER BOAT



PLUGGING into the Sun®

SEND US YOUR COMMENTS

ASSEMBLY GUIDE

Flexible solar cell
turns sunlight into
electricity ...

... that flows through
the solar motor
making it spin ...



... resulting in a
forwards force on
the boat allowing it
to move through
the water.

... that connects to
the propeller which
forces water
backwards ...

©Schools & Homes Energy Education Project. All rights reserved 2006.

Use password **morephotons** on website to download solar notes. Use password **bodyshop** to download templates and instructions for building car shell. Tel/Fax/minicom 0114 2499 459. enquiries@pluggingintothesun.org.uk - www.pluggingintothesun.org.uk

PARTS LIST:

1 or 2 - 1Q or
1 - 2-Q PV
cell



1 propeller

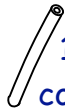

1 shaft
connector
tube

plastic
cards

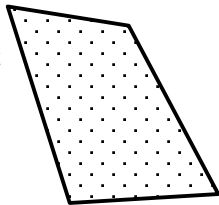

1 self-adhesive
motor mount

1 steel
propeller
shaft

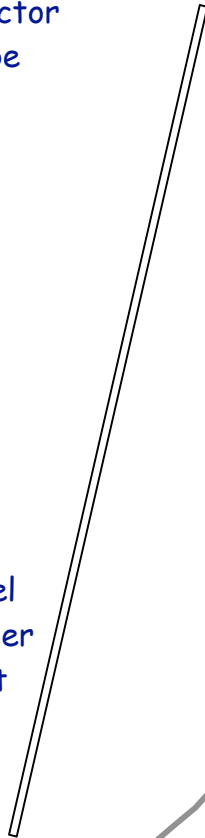

Velcro hook
(spiky) &
loop(furry)

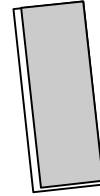

Drive shaft
support

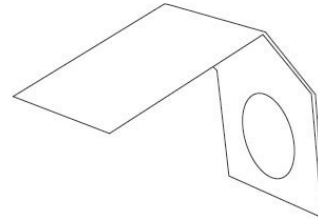

1 solar
motor with
gold plugs

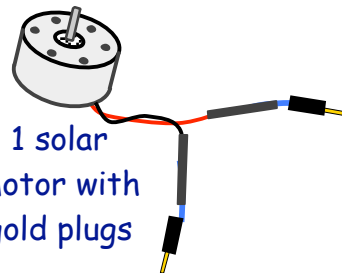

2 plastic
bottle hulls

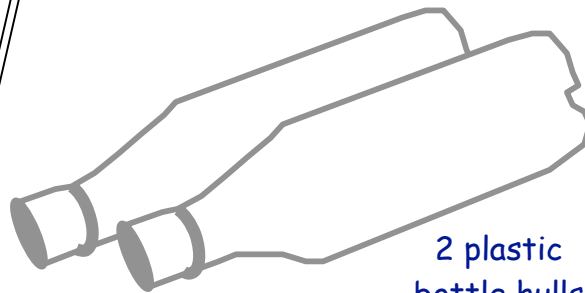

How does a boat float and propel itself through the water?

Find out from the science and component notes extracted from our website to the appendix of this guide. >>>

SOLAR CELLS & ELECTRIC MOTOR

PV cells, motor, connection wires

1.0 PRE-BUILDING ACTIVITY

1.1 Connecting solar cell to motor (& testing)

A solar cell has a positive terminal (marked by a red dot) and a negative terminal. Identify these components.

Electrical Connections with Pinch Terminals

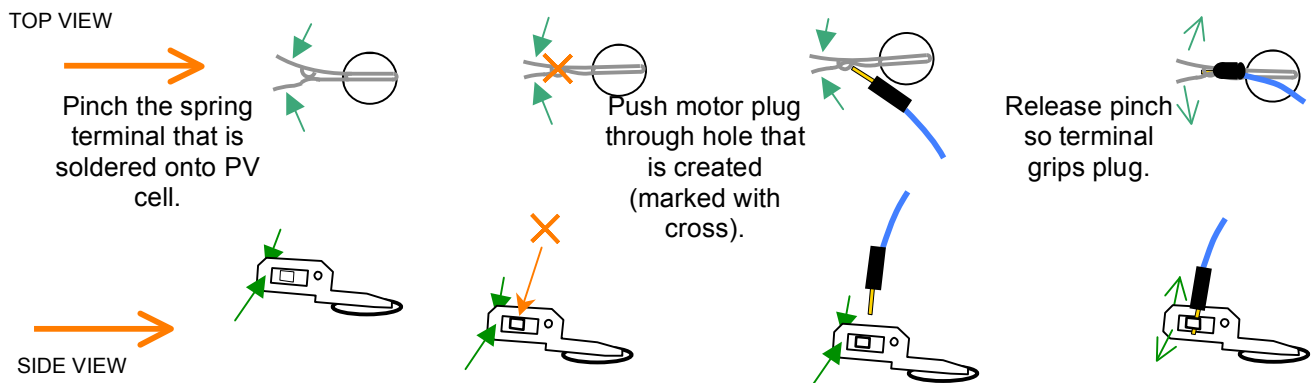

1.2 Connect the positive terminal of the PV cell to one of the wires of the motor and connect the other wire of the motor to the negative terminal of the PV cell.

NOTE: If you connect the red motor wire to a positive terminal & black motor wire to a negative terminal, the motor shaft will spin clockwise. Swap motor plugs between terminals to change direction in which motor runs.

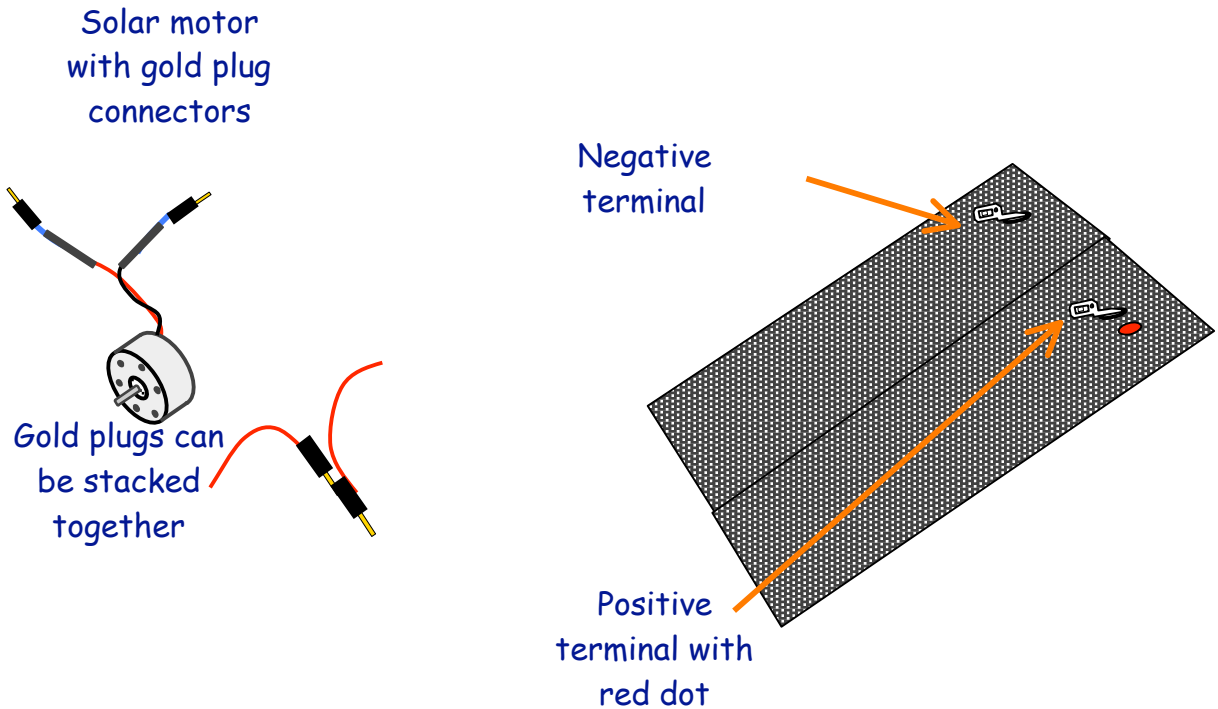

SAFETY: Risk of electric shock. If an electric lamp is used to illuminate the solar cell then take great care to avoid splashing the lamp with water. DO NOT HOLD ELECTRIC LAMPS OVER WATER.

1.3 Direct collector side of solar cell towards a bright light source and check that the motor spins. Please read: *How much light does the solar (photovoltaic*) cell need?*

1.4 Disconnect the motor and solar cells from each other.

PROPULSION SUB-ASSEMBLY

motor, connection tube, shaft, propeller, motor mount, plastic card

2.0 Assemble motor mount from plastic card, motor clip and Velcro using or simply use motor clip assembly from solar car and attach to Velcro pad - step 2.2. as shown in picture below.

2.1 Stick the self-adhesive black clip to centre of card noting orientation in picture. The motor will hang from this clip.

Top Down View

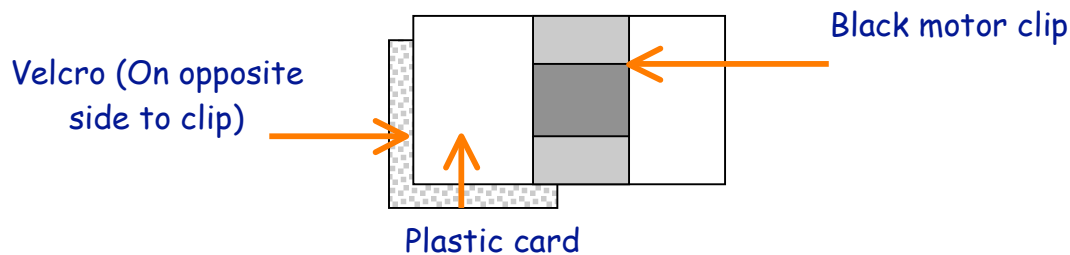

2.2 Turn the plastic card over and stick a Velcro loop/furry pad on the underside of card as in the picture. It will be later placed on the central 2X2 cm Velcro hook pad of the PV cell.

3.0 Fitting motor to clip

3.1 Push motor into clip.

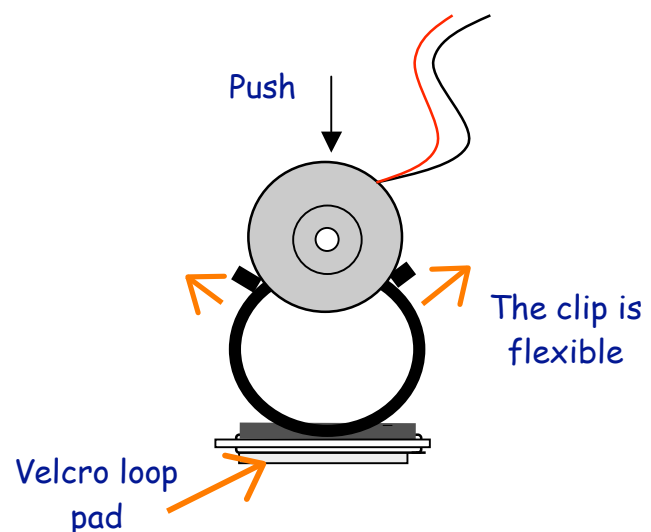

4.0 Connecting propeller to propeller shaft

Safety: The propeller shaft is thin and could potentially pierce the skin. Do not push shaft towards the palm of your hand at anytime.

4.1 Screw the propeller onto the shaft.

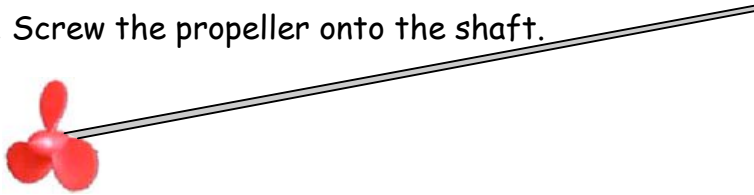

5.0 BOAT STRUCTURE

Plastic bottles, Velcro hook & loop, PV cells

The PV cell connects the two bottle hulls of the boat

5.1 Press the strips of Velcro loop pad & hook pad together.

5.2 Remove backing paper from hook pads and stick to cell in positions shown in picture.

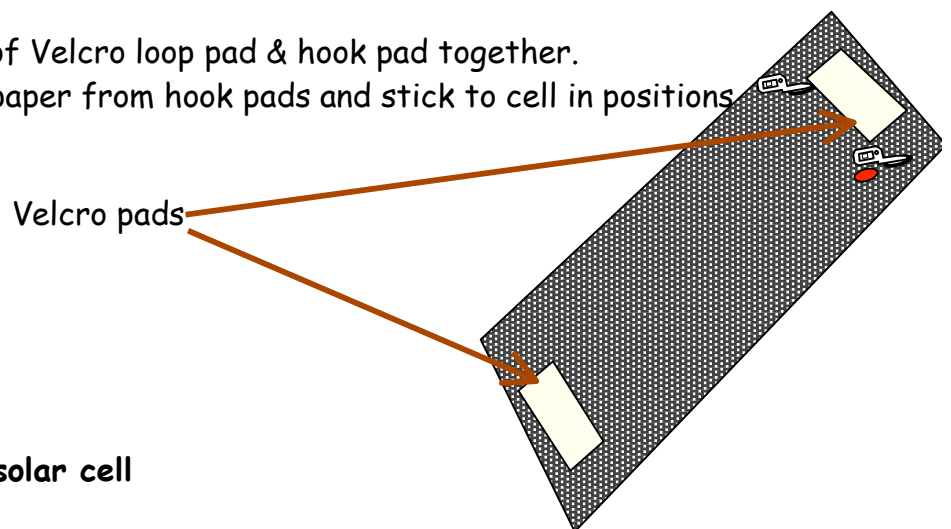

Joining hulls and flexible solar cell

5.3 Remove backing tape from the two Velcro loop pads on the cell and stick to bottles as in picture below.

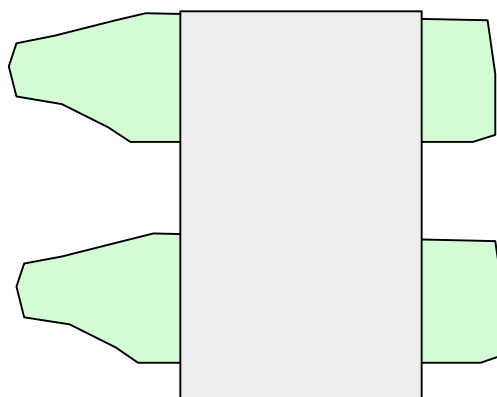

6.0 FIXING PROPULSION PARTS TO BOAT

Velcro hook, propulsion sub-assembly (motor, motor mount etc.) and boat structure

6.1.1 Place foam ds tape onto cell near base of bottles and stick 2cm x 2cm Velcro hook over ds tape in position as shown in illustration.

6.1.2 Stick the 2cm x 4cm velcro hook pad at the outer edge of the cell between the necks of the two bottles, in position as shown in illustration.

Velcro hook pads

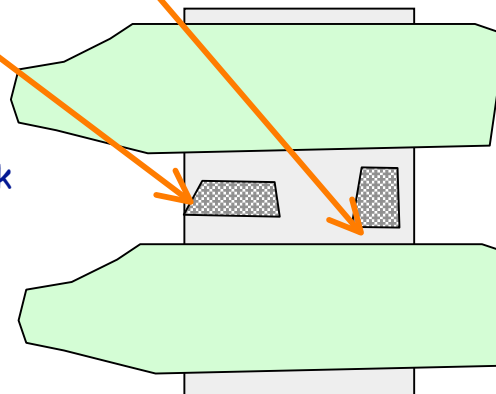

6.2 With motor **hanging underneath**, join Velcro loop pad on motor plate to hook pad on the cell as shown in picture below. Then attach the Velcro loop pad on the prop shaft support to the hook pad on the rear underside of the cell.

Folded card with 'o' cut out

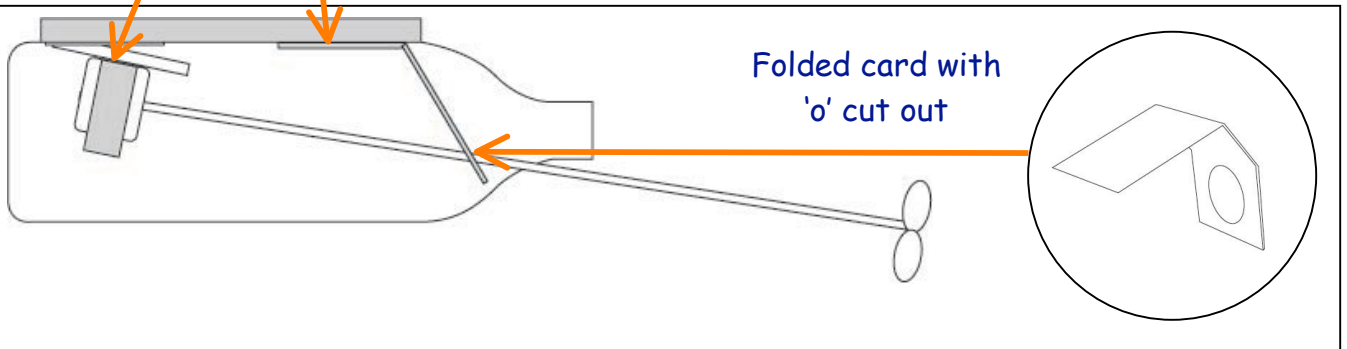

Note: The propeller shaft should extend away from boat at the same end to bottle tops. Ideally, to get the boat to go 'fast', the angle of the shaft on entry into the water needs to be as shallow as possible. Ideally, a straight line should flow from motor - to shaft - to surface of water. IT WILL BE NECESSARY TO ADJUST THE ANGLE OF THE MOTOR PLATE TO FACILITATE SHAFT ENTRY INTO WATER TO BE AS SHALLOW AS POSSIBLE. A **second hole*** has been placed just **BELOW** the shaft support hole. This hole is to attach string or fishing line to ensure you do not loose boat when testing boat in a local lake. [*Rona Khatun of the S O U T H T Y N E - S I D E C O U N C I L Energy Conservation team devised this during a training workshop.]

Electrical connections.

6.3 Reconnect the solar cell and motor as described at the beginning of this guide. Ensure the wire will not fall into the water when the boat is in operation.

6.4 In this design the shaft needs support and this support is placed just behind the motor.

6.4.1 You can make the support from the folded card with a 'o' cut out as shown in picture on previous page. The support is already provided and extra card to make another.

6.4.2. Place Velcro spiky pad on top side of 'o' cut.

6.4.3 Take the 'o' cut support and attach to furry Velcro pad on solar cell just behind the motor holder as shown in the picture above.

7.0 Connecting motor to propeller shaft

A piece of tubing connects the propeller shaft to the motor shaft.

7.1 Push $\frac{1}{2}$ the tubing onto propeller shaft or it may already be in place.

7.2 Slide the shaft through the prop shaft support and push the other $\frac{1}{2}$ of the tubing onto the shaft of the motor. **Be careful that the end of tubing does not touch the motor.**

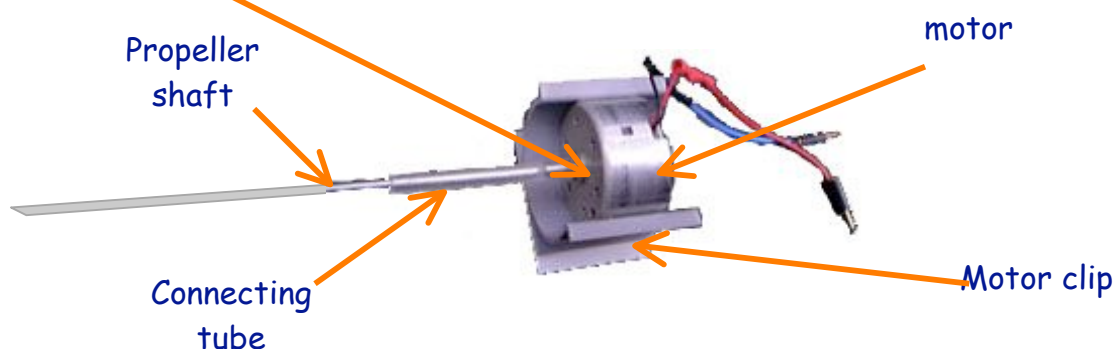

The propeller will spin at the same rate as the motor.

NOTE: To test you may wish to connect a 1.5 volt battery or connect to the PV cell to make sure the mechanism runs smoothly.

8.0 LAUNCHING & SAILING THE BOAT

Safe body of water, model solar boat

Safety near water: Find a safe place to sail your solar boat. It needs about 10 centimetres depth of water to float. Beware of unstable banking and unsafe bodies of water. Build a water testing rig from recycled cardboard. Contact enquiries@solar-active.com for instructions.

How much light does the solar boat need?

In a correctly assembled kit given suitable lighting conditions the solar cell supplies more than enough electricity to spin the propeller and propel the boat. Optimum performance is always achieved under natural lighting conditions when the cell can 'see' as much of the sky as possible. Diffuse sunlight from a cloudy sky will normally provide enough energy for the boat to run. Remember the solar cell is designed for daylight wavelengths (including light scattered by cloud cover), not the wavelengths given off by artificial light sources.

The motor must be kept dry at all times. Cover it with a balloon.

SAFETY: Never use an electric lamp to illuminate the solar cells when the boat is in water. There is a danger of electric shock if water and mains electricity come into contact. There is no risk of electric shock from cell.

PROBLEM SOLVING GUIDE

Problem	Check Items ⇒ Solution
boat goes backwards	<u>polarity</u> reversed ⇒ reverse terminal connections
Propeller does not turn or boat goes very slowly	<ul style="list-style-type: none"> • <u>Insufficient light</u> intensity ⇒ read 'How much light...' • Tubing of propeller shaft <u>touching</u> motor • Tubing is <u>bent</u> or <u>loose</u> on propeller shaft • <u>High electrical resistance</u> ⇒ check soundness of connections between motor plugs and solar terminals ⇒ check for broken motor wires • <u>Bent propeller shaft</u> ⇒ remove propeller and check it by rolling on a smooth surface and straighten if necessary • Solar cell being <u>shaded</u> by sides of water rig or by a person standing near the water rig. • <u>Friction</u> between propeller shaft and shaft support • <u>Angle of shaft</u> in water

VISIT: www.pluggingintotheshun.org.uk/sonsun.gallery.htm
for more designs using our solar cells.

Appendix A: How much light does the solar (photovoltaic*) cell need?

A bright light source has more energy!

A solar cell converts light energy into electrical energy. If the intensity of light falling on the cell goes down, the electrical power output falls also. The electrical current output from the cell is very sensitive to light intensity. Maximum power output is produced when the incident light beam (i.e. when it is pointed at the sun) is perpendicular (90 degrees) to the cell surface.

Solar power is best obtained from the sun!

The UNI-SOLAR solar cell is designed for daylight or natural wavelengths of light (including diffuse light i.e. light scattered by cloud cover), not wavelengths from artificial light sources. However, soft white fluorescent lighting works best with cell.

The power output of the solar cell will be diminished in inverse proportion to the square of the separation distance from the light source to the surface of the solar cell. In other words, the motor in our solar car/boat kits will work by putting the solar cell directly under the artificial light source but if you double the distance you will only get 1/4 of the light intensity and the motor will probably stop working.

Dull days!

Diffuse sunlight from a cloudy sky can provide enough energy for the solar motor of the car/boat or mini-water pump to spin – but not always to run these devices. For the car, it will depend on gear ratio, wheel surface and size, the surface that you run the car on, time of day and season.

Solar radiation is very variable – from place to place, from time to time and from season to season. For example, in the UK during the winter months, when the sun is 'lower' in the sky, diffuse sunlight may not run the car during the early morning hours but by mid-day the car will work.

OK so there is no sun at all today...

A 100W standard tungsten filament bulb held closely to (but not touching) the collector side of the solar cell will spin the motor. However, it is not the way to show how solar energy works. Remember that about 95 of the 100watts going into the lamp is given off as heat not light! Beware of burns to hands and melting plastics. A halogen security lamp (500w), OHP projector lamp or high intensity spotlight will power the car, but again the heat build-up is a safety issue. **Low energy lamps will not power the motor.**

Explaining natural energy use

Natural energy sources such as the sun, the wind and waves vary in intensity all the time. Harnessing and storing this energy is an important aspect of renewable energy, which is well illustrated by this solar electric model car kit.

Please try not to demonstrate solar power in very poor light conditions, unless you already know that the electrical device can work under those conditions. For example, a 12V piezo buzzer will work under poor light conditions with the solar cell in this kit.

(* The term '*photovoltaic*' is derived by combining the Greek word for light, *photos*, with *volt*, the name of the unit of electromotive force.)